

# TOP GUN

DIFFERENT TYPES OF DISTRIBUTOR CAPS, COMMON & EUROPEAN

## COMMON & EUROPEAN DISTRIBUTORS

### STANDARD SOCKET DISTRIBUTOR

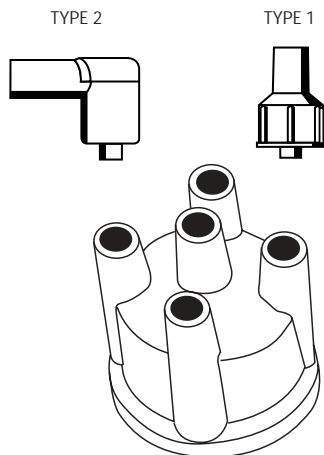

### POST TYPE (HEI) DISTRIBUTOR

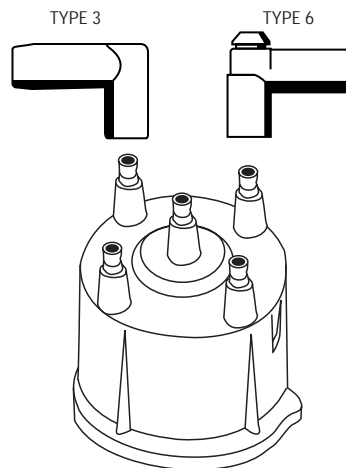

### RECESSED PIN DISTRIBUTOR

BMW, VOLVO etc.

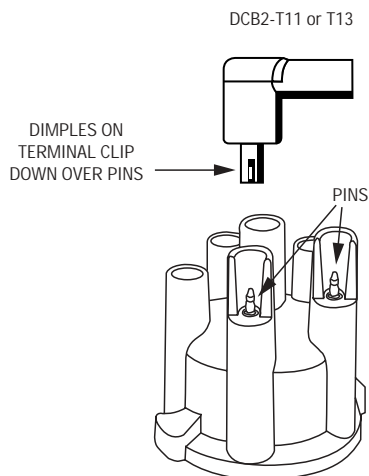

**Please note:** Top Gun kits for BMW vehicles feature special (dimple) distributor terminals designed to fit either European pin style or standard socket distributors.

### EXTERNAL PIN/POST DISTRIBUTOR

MERCEDES, PORSCHE etc.

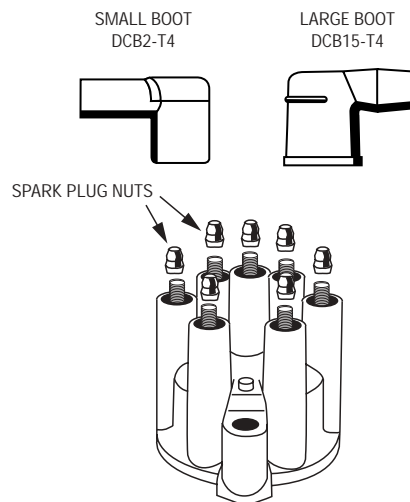

**Please note:** Many Mercedes & Porsche distributor caps come with protruding (threaded) pin fittings (see diagram). Top Gun kits for Mercedes & Porsche vehicles are supplied with spark plug nuts to be fitted to these pins, allowing the use of a post style terminal i.e. T4